

2e etage

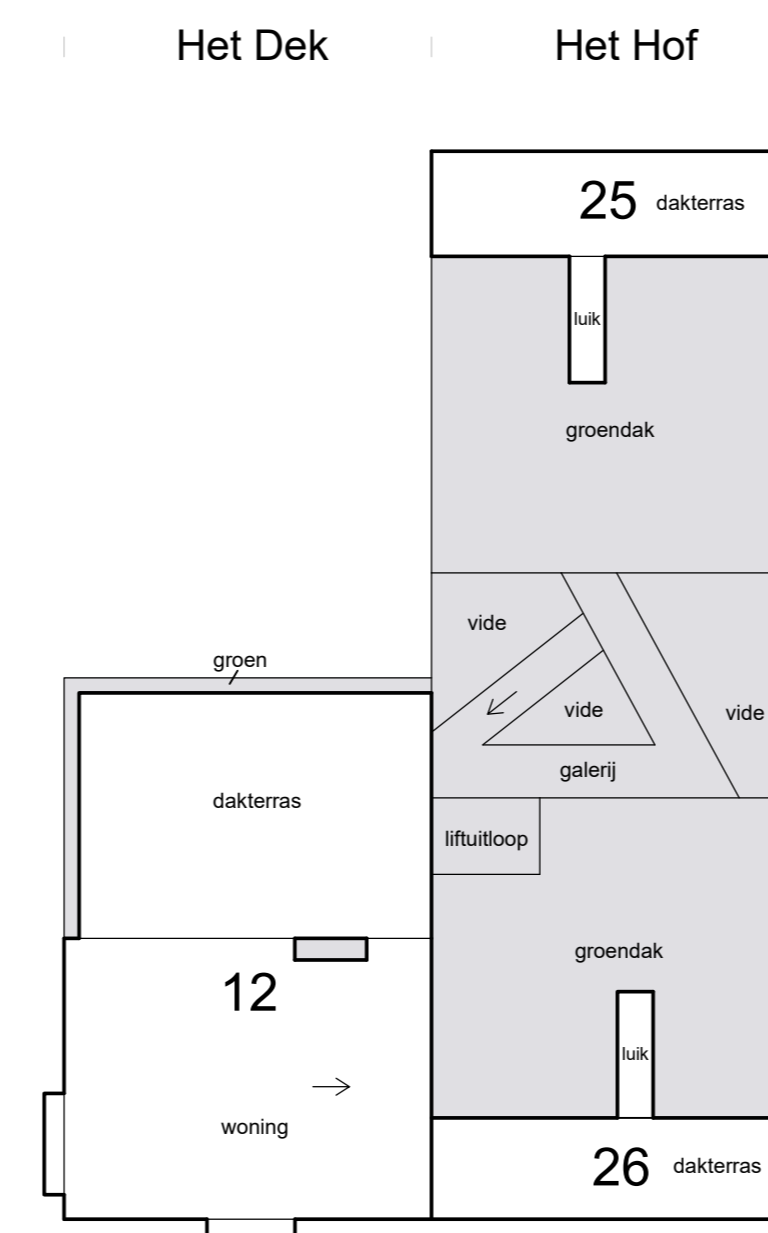

5e etage

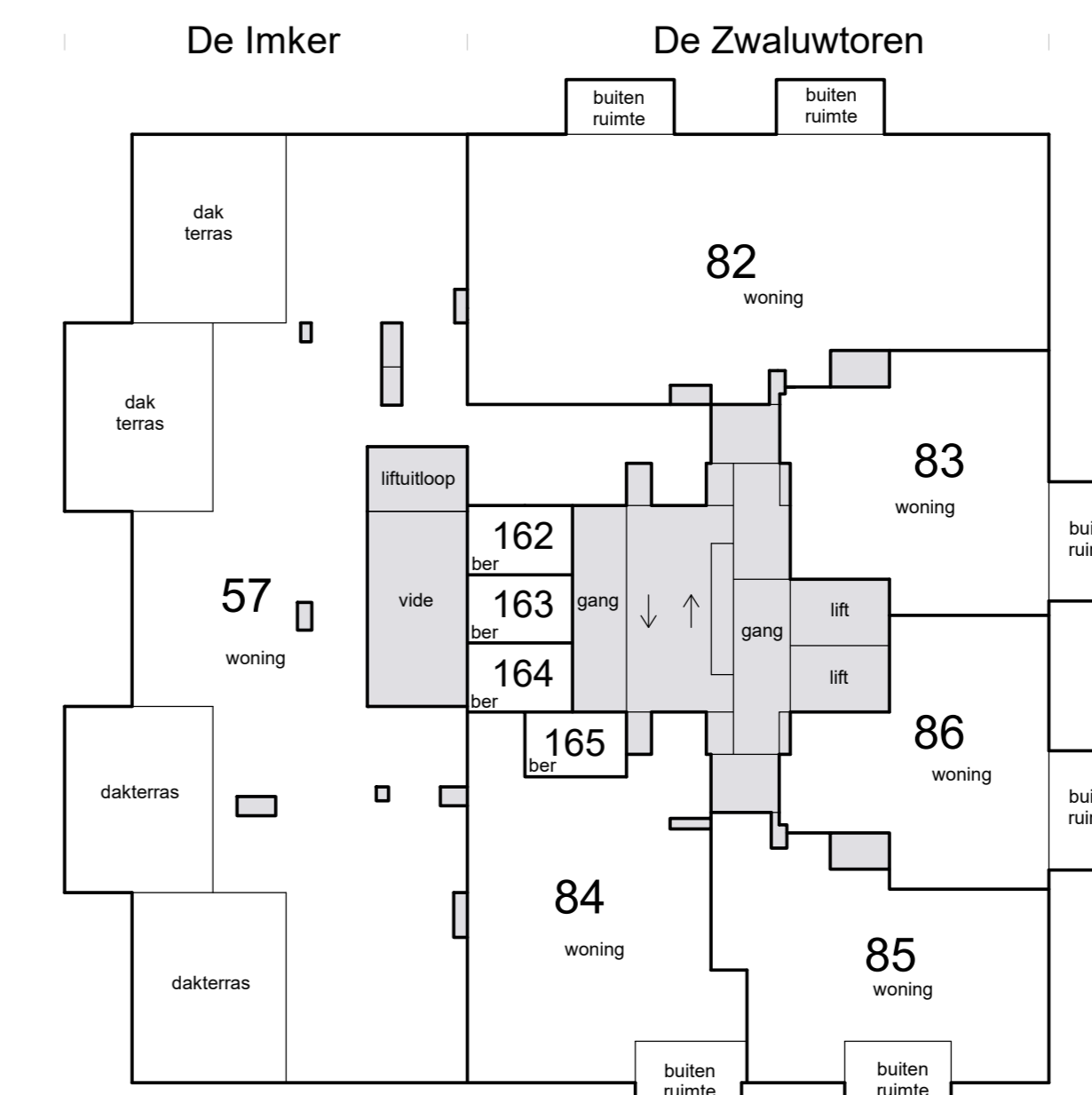
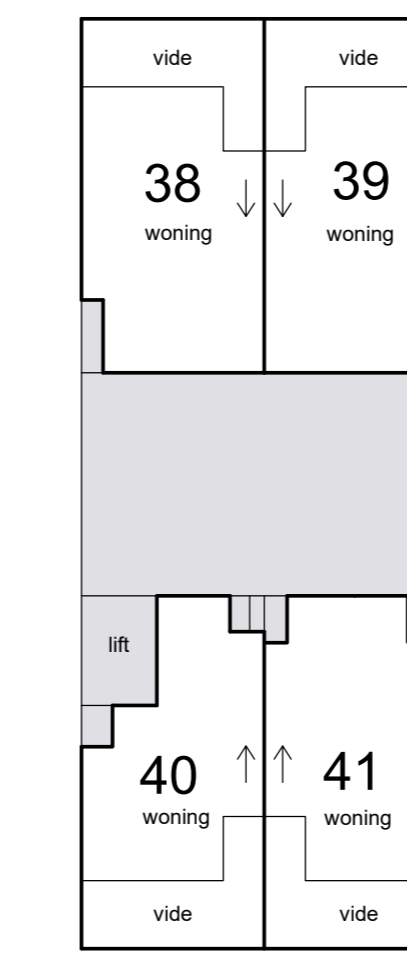

Schaal 1 : 200
 = Gemeenschappelijk
 Tekening bestaat uit 3 bladen
 Blad 1

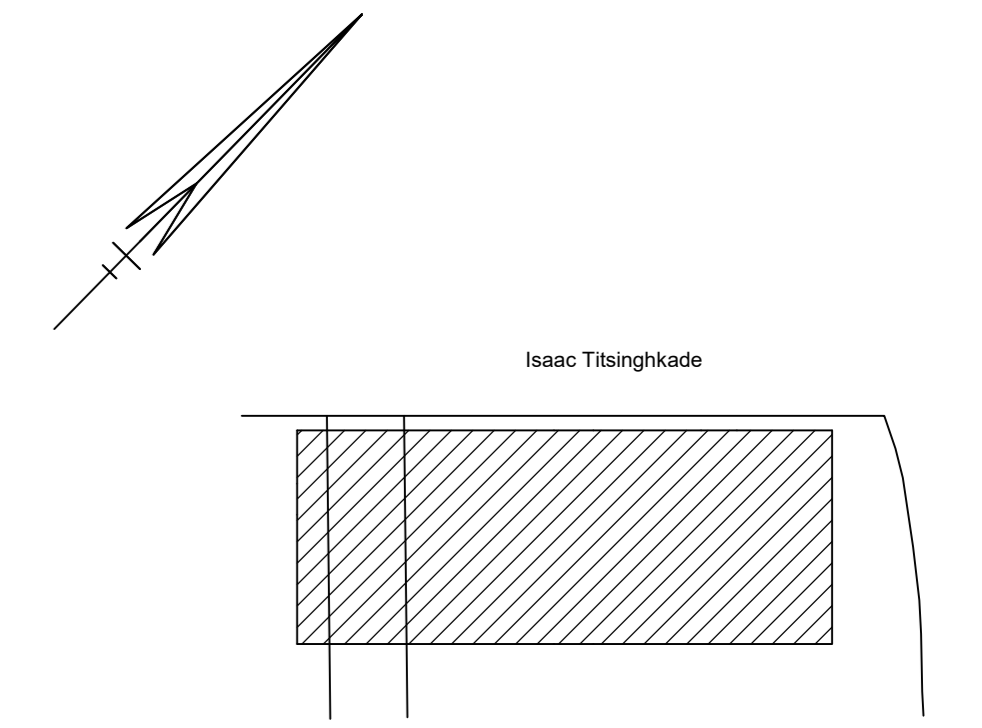

Situatie 1 : 1000 Amsterdam N 4740, 4742 en 4743

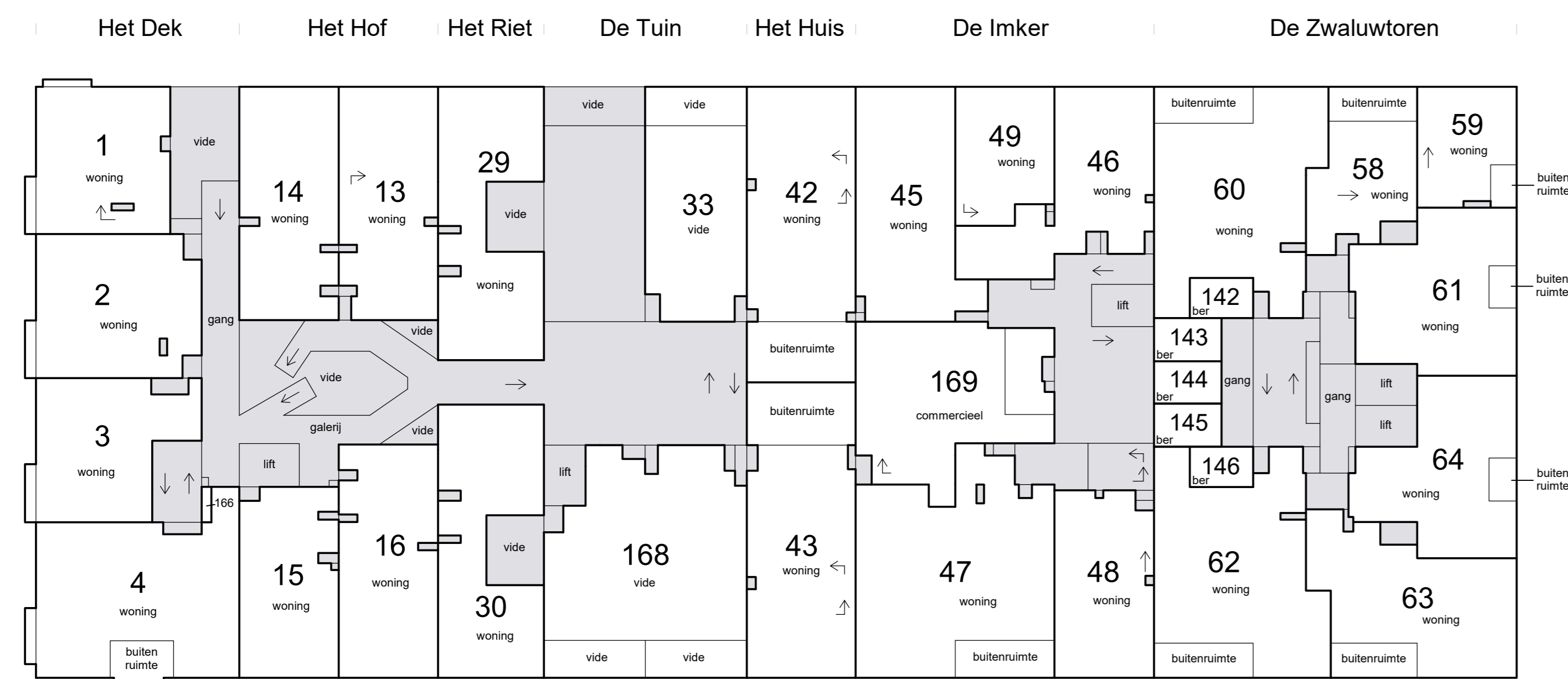

1e etage

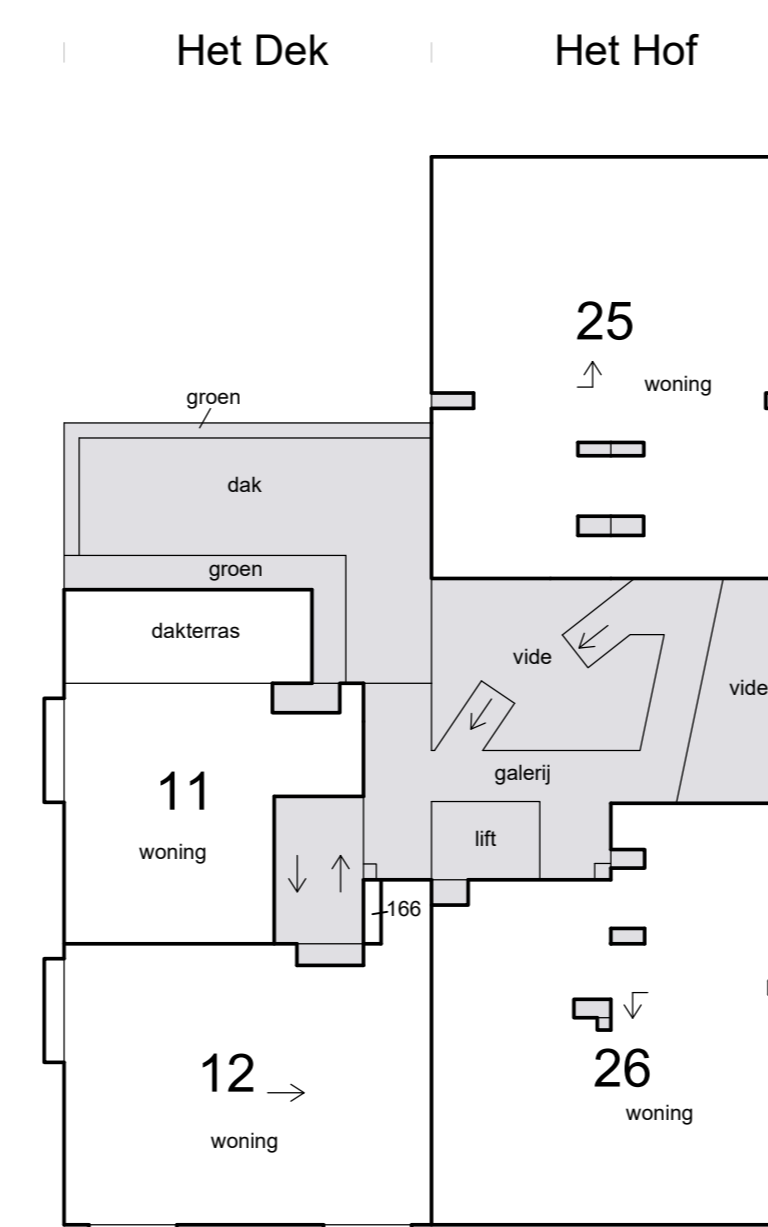

4e etage

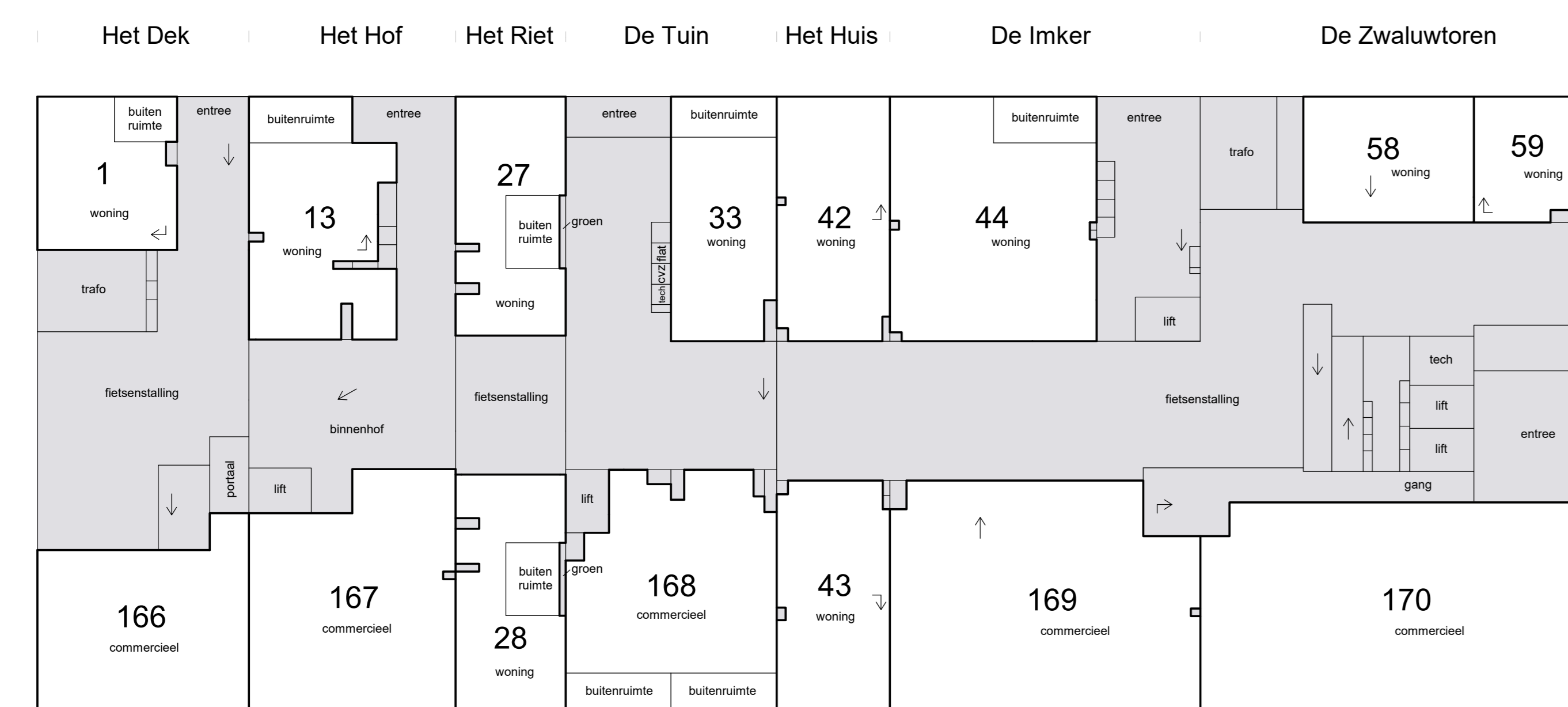
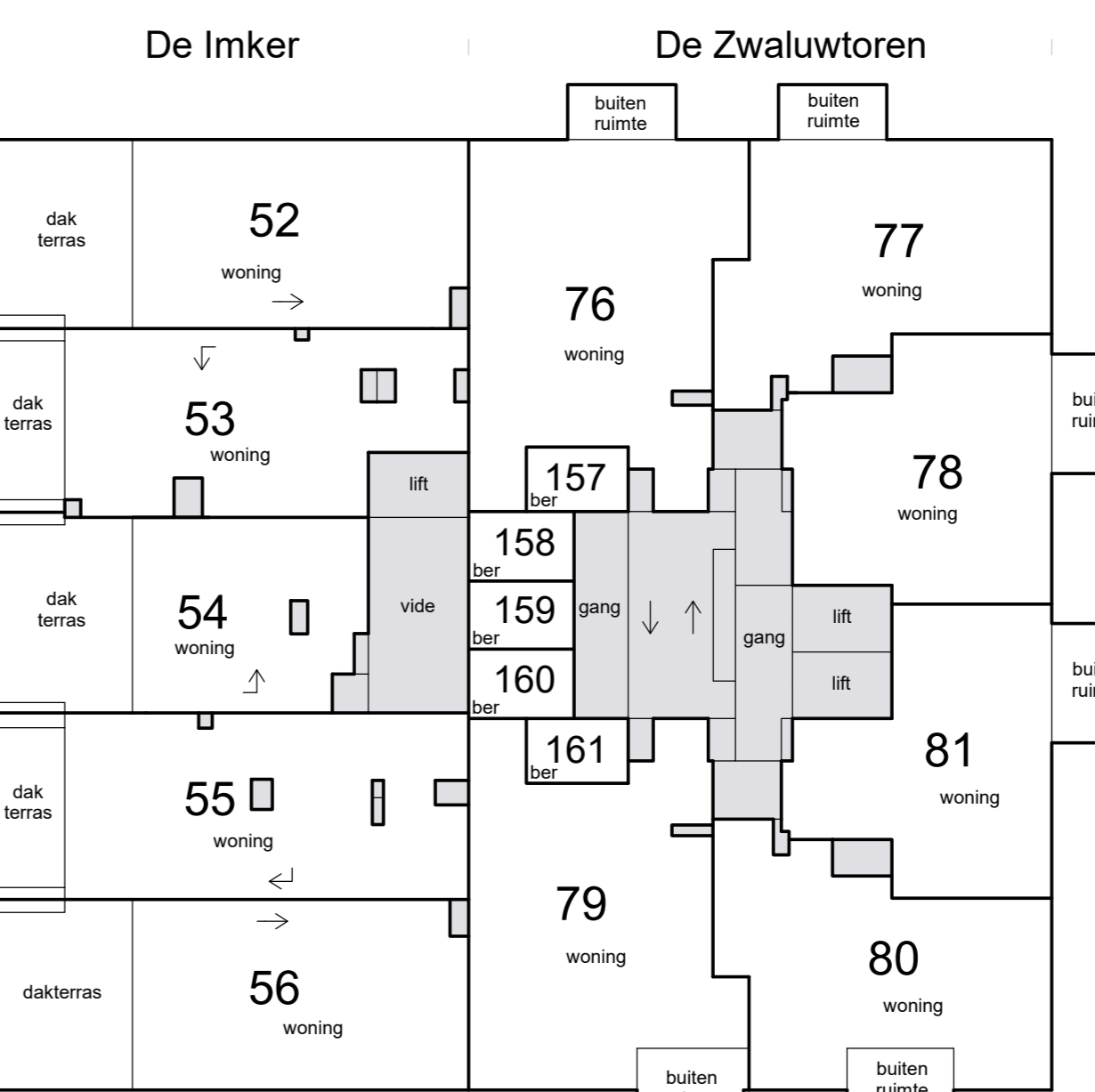
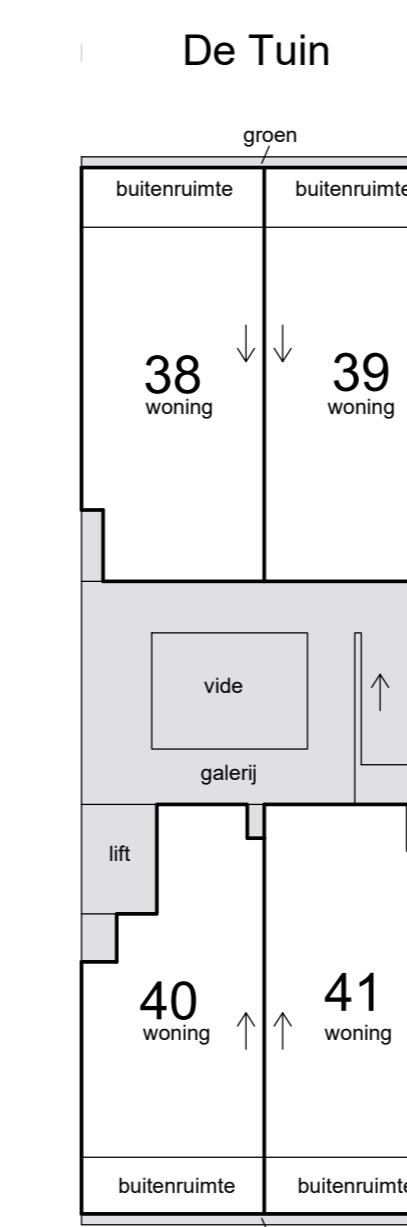

begane grond

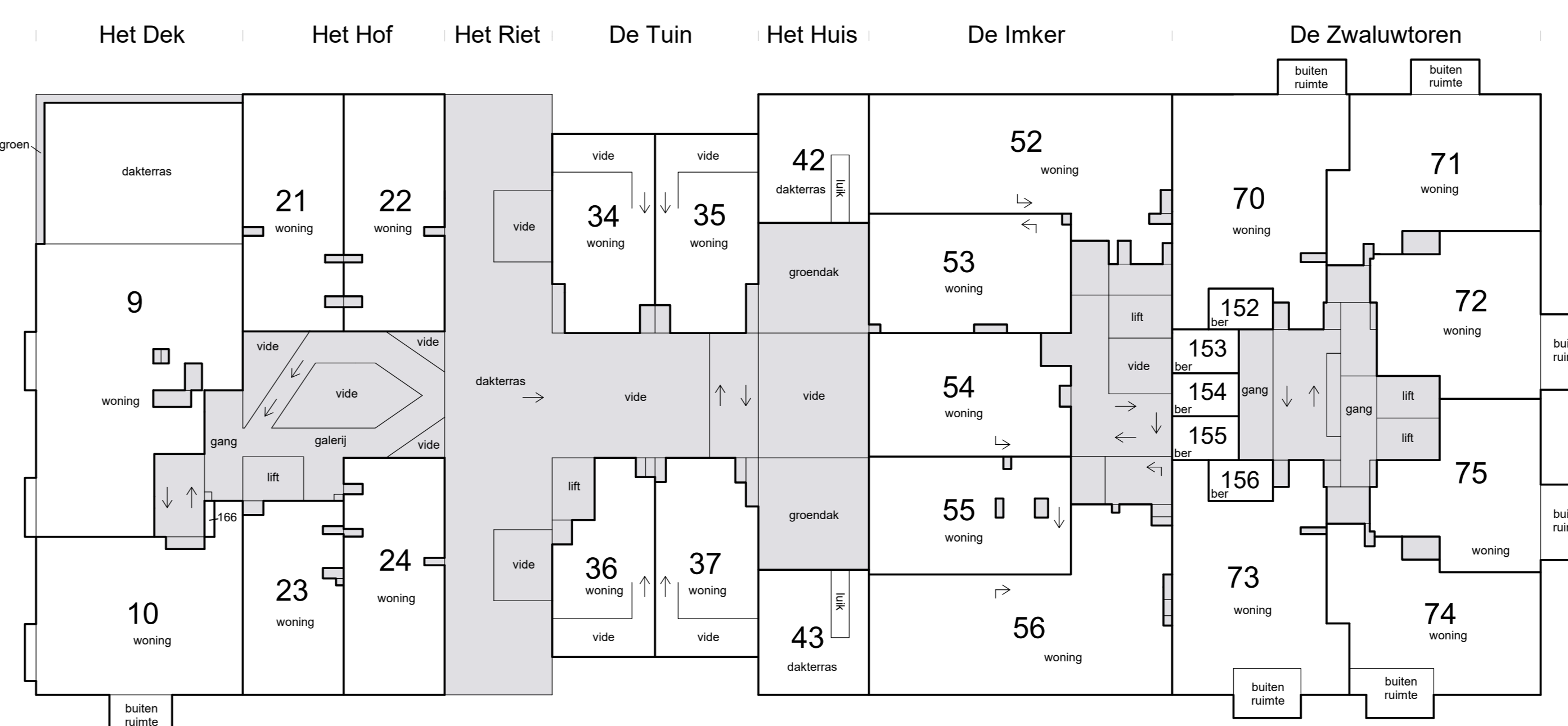

3e etage

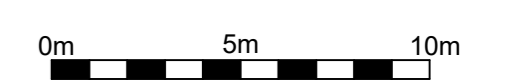

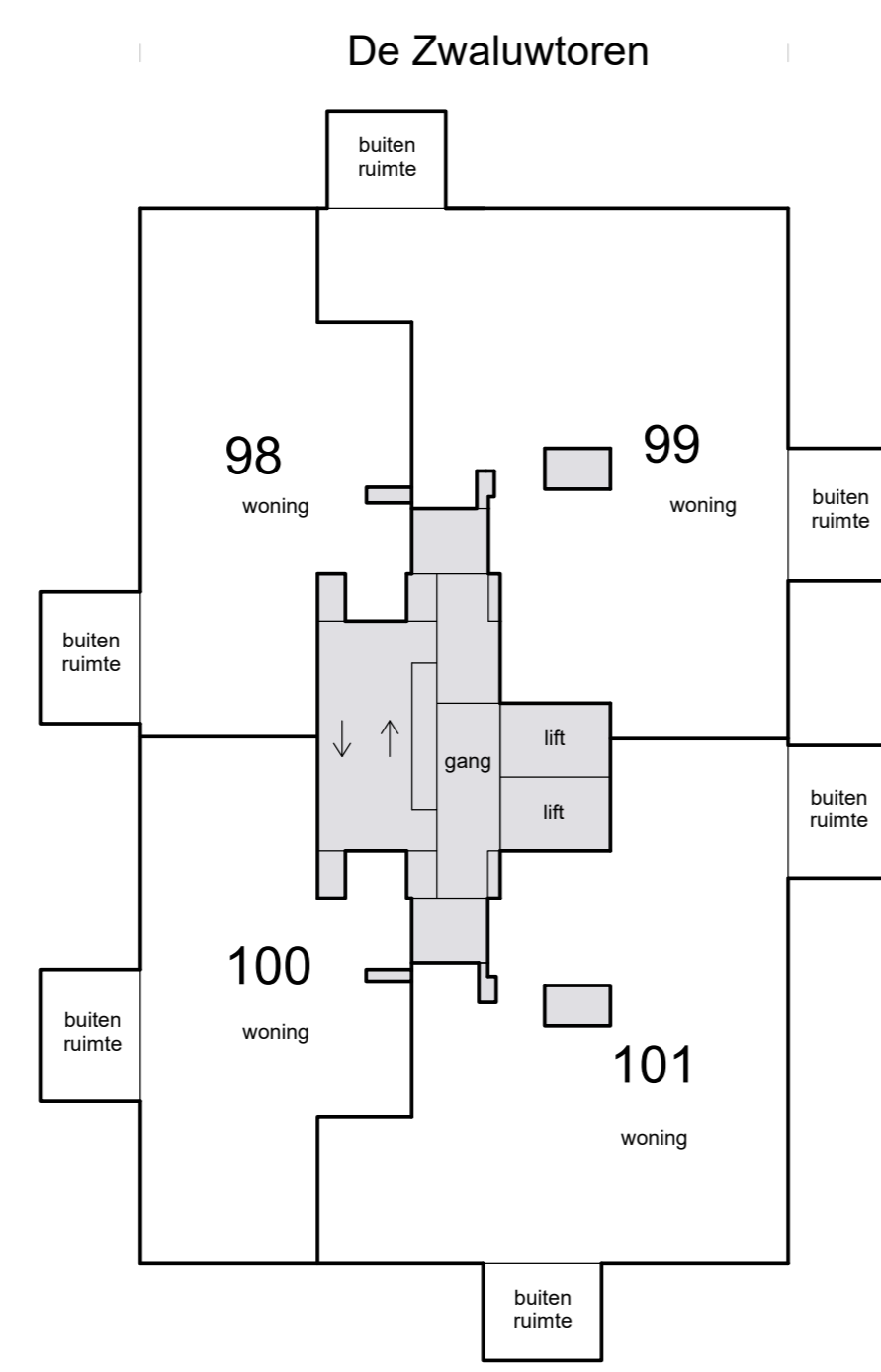

8e etage

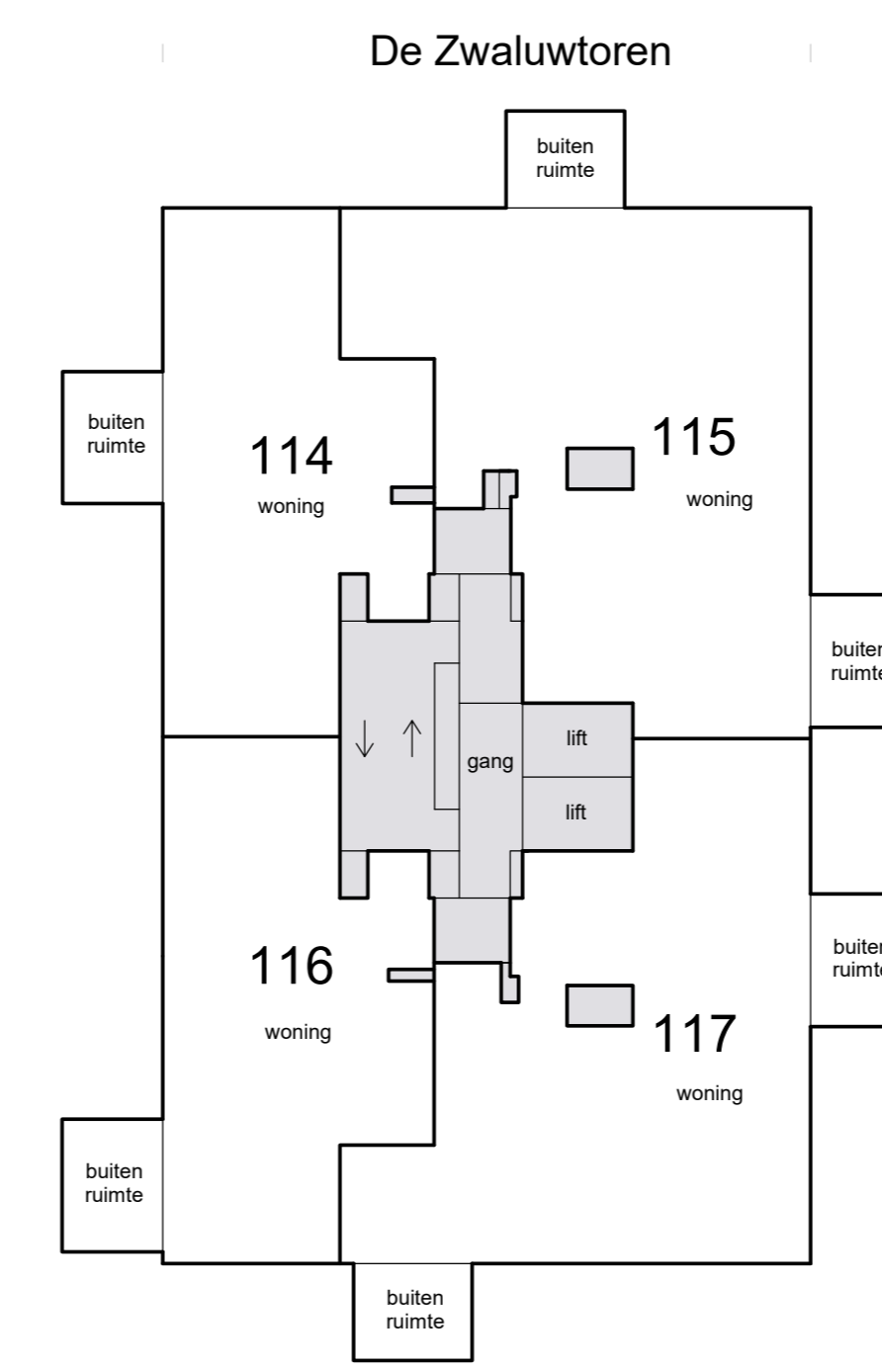

11e etage

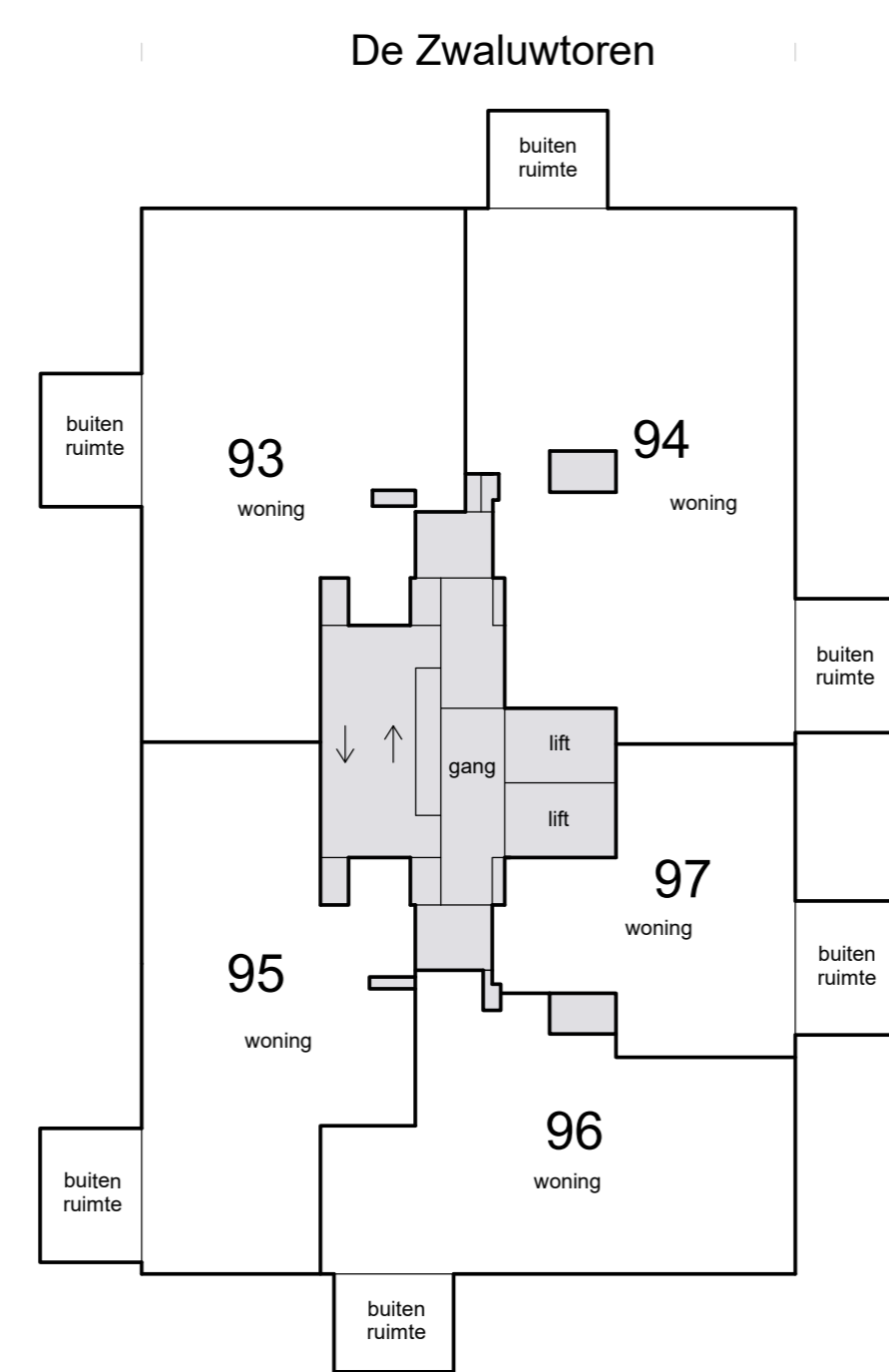

7e etage

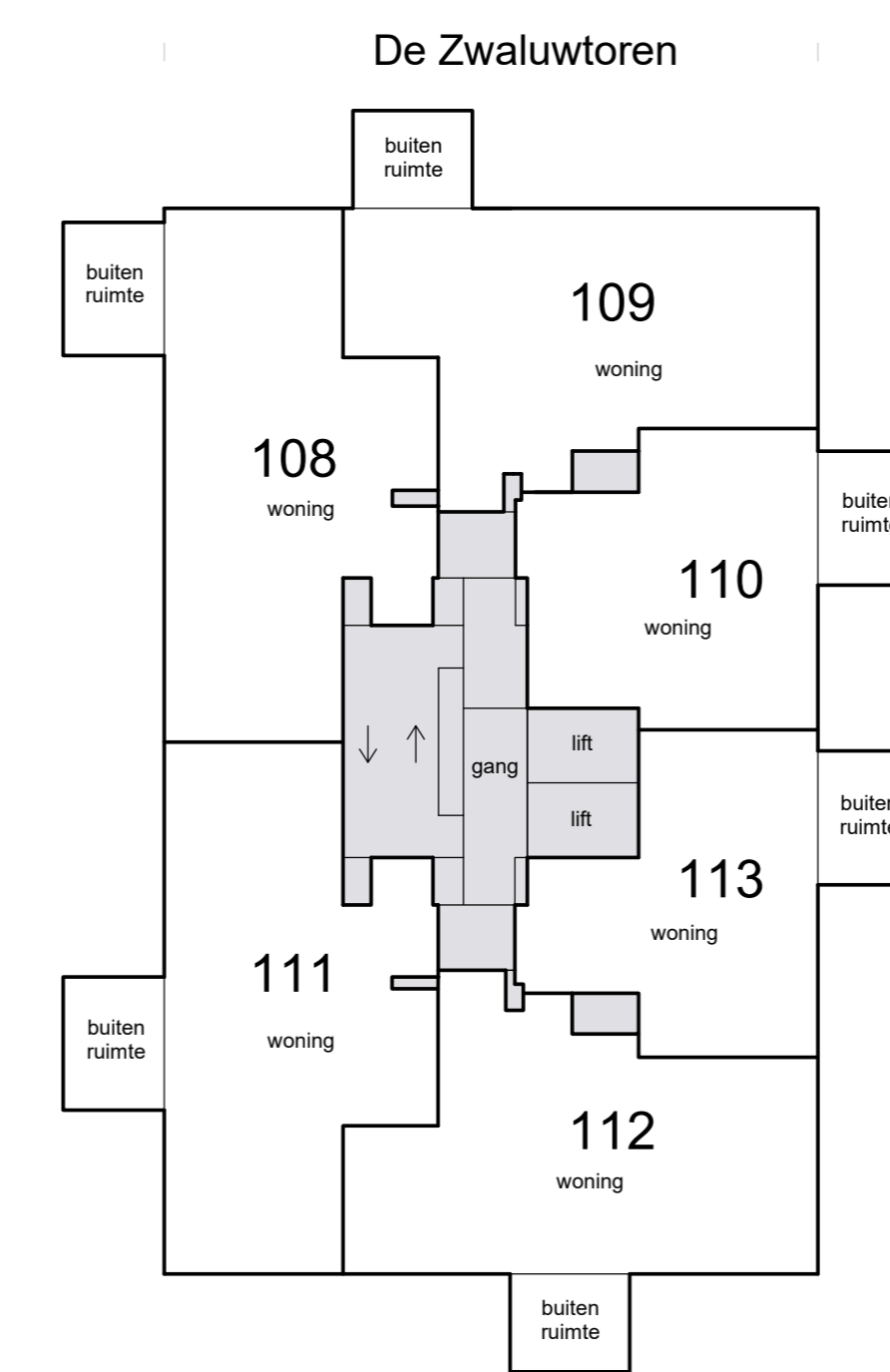

10e etage

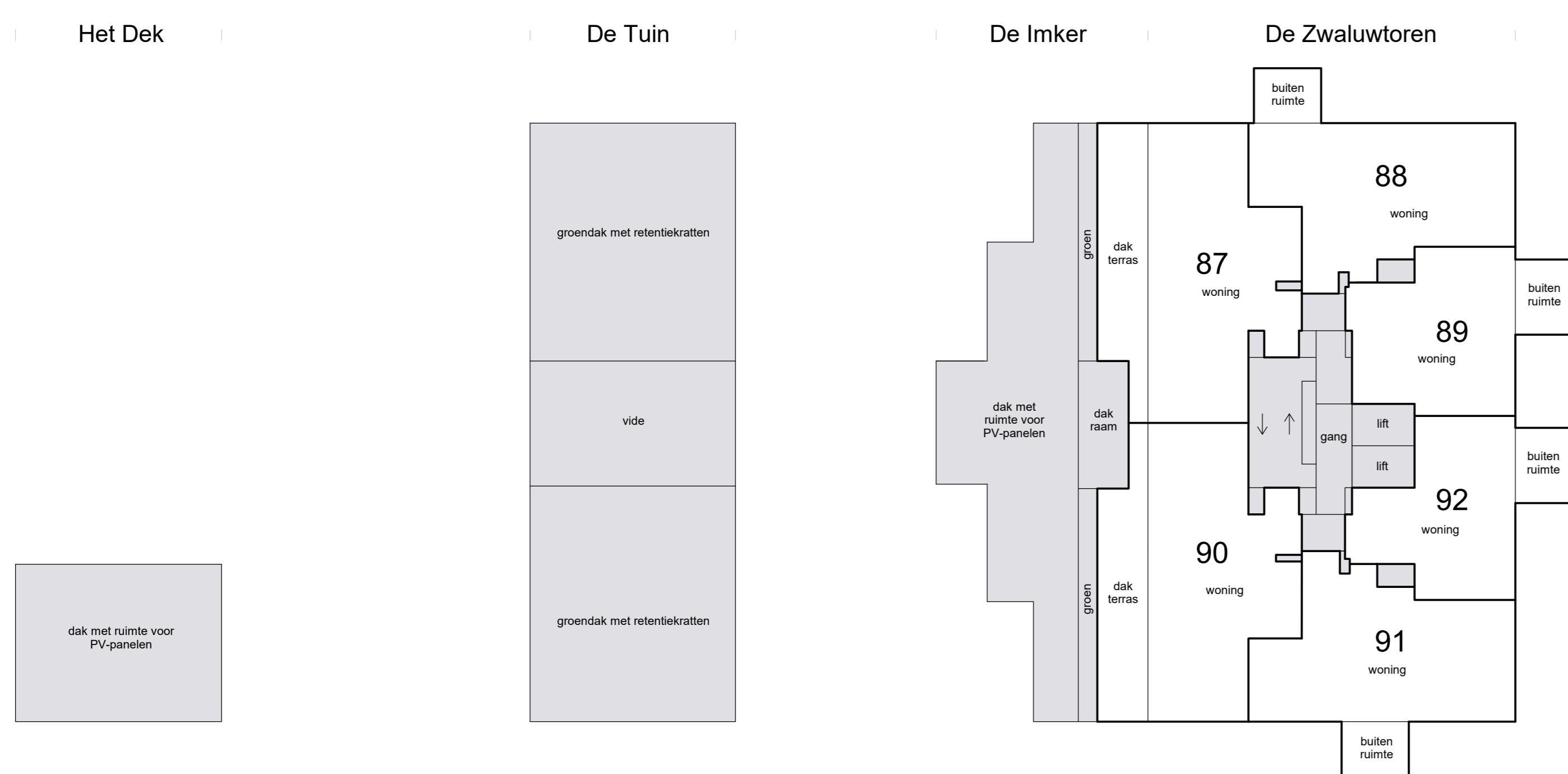

6e etage

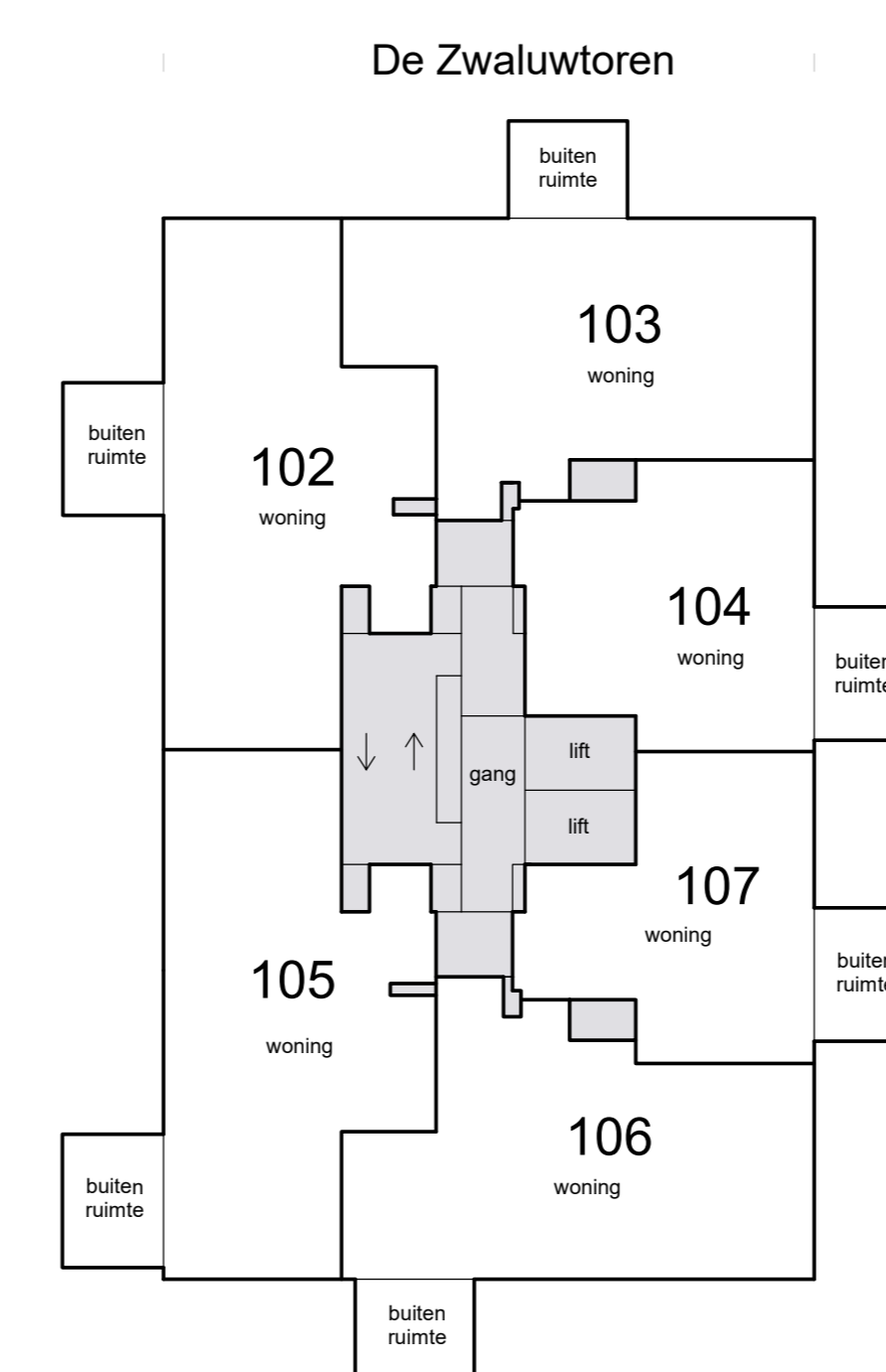

9e etage

Schaal 1 : 200
 [shaded box] = Gemeenschappelijk
 Tekening bestaat uit 3 bladen
 Blad 2

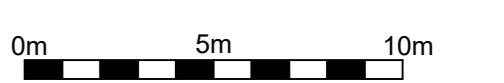
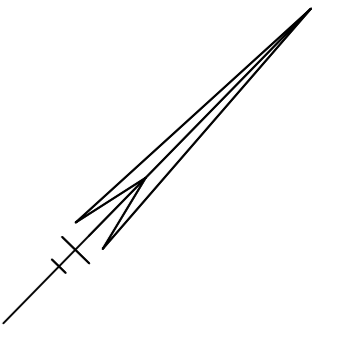

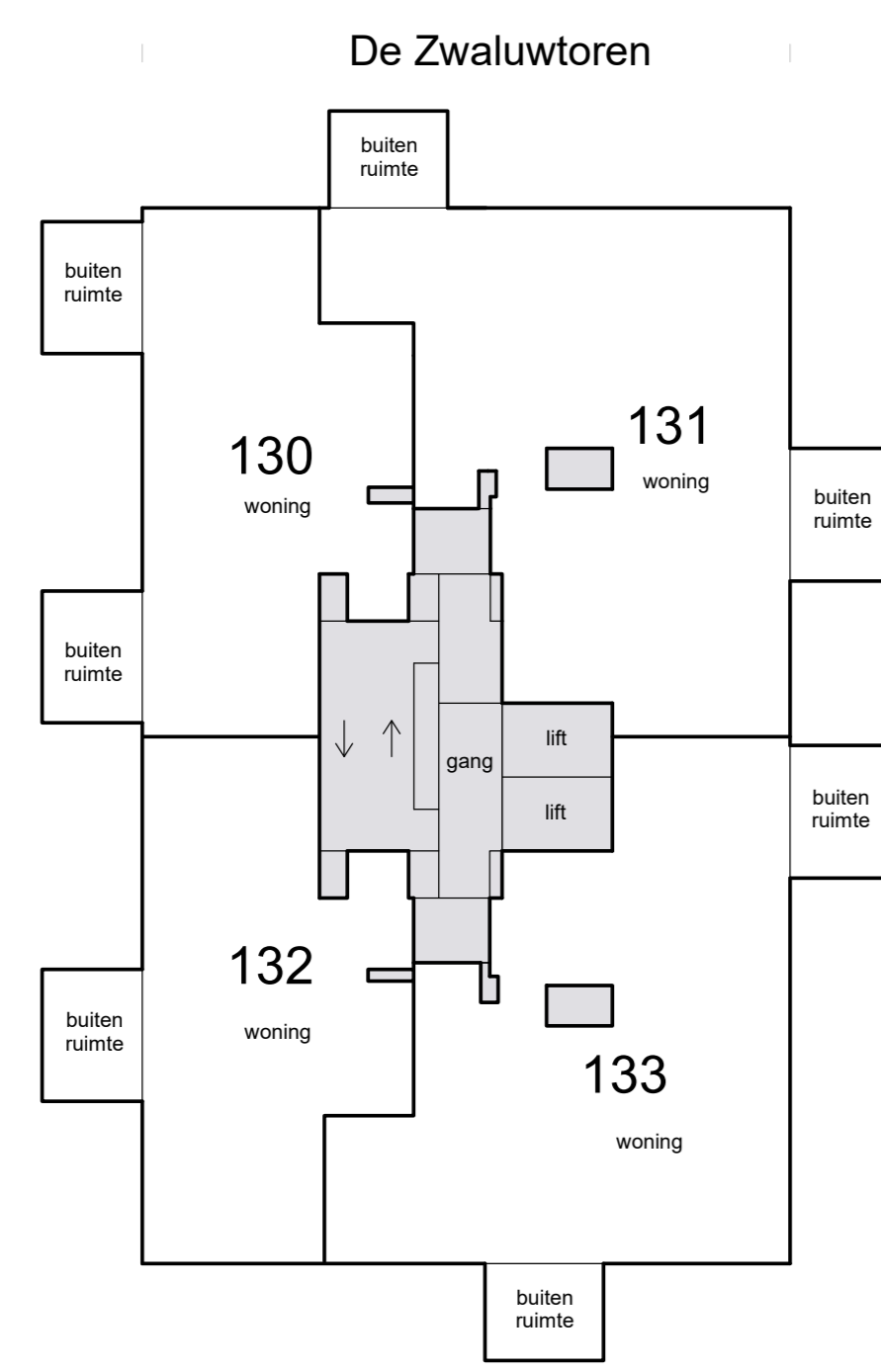

14e etage

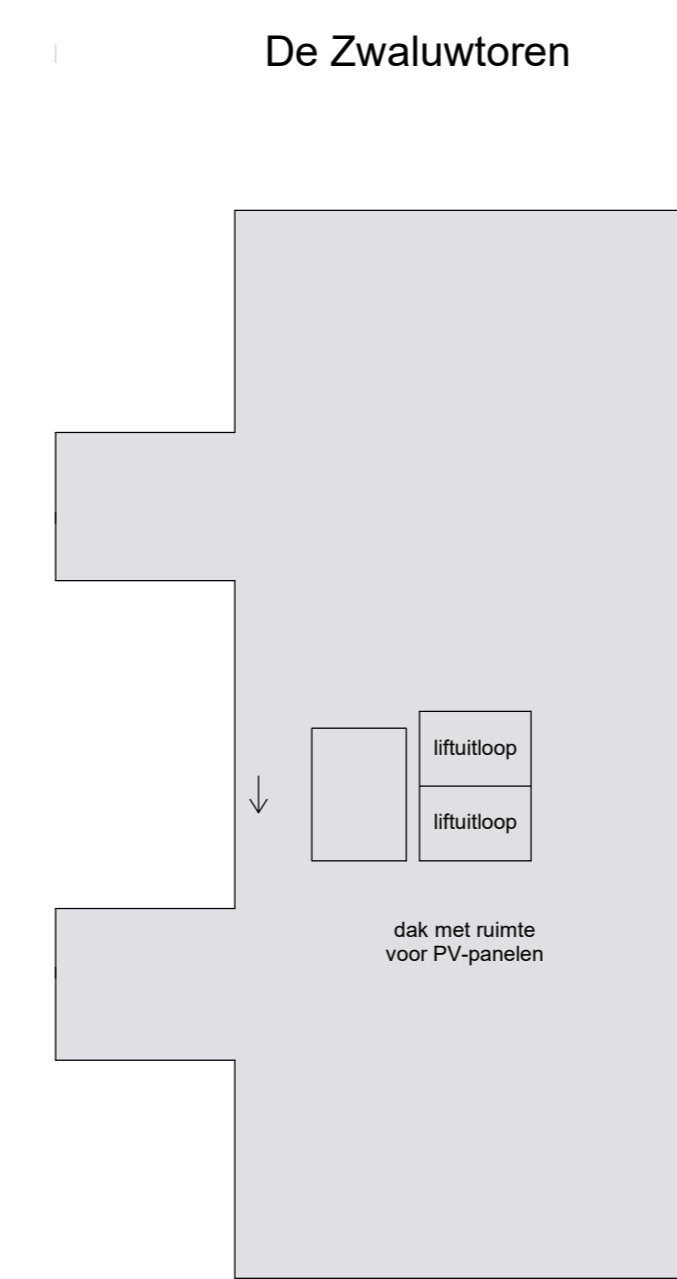

dak

Schaal 1 : 200
= Gemeenschappelijk
Tekening bestaat uit 3 bladen
Blad 3

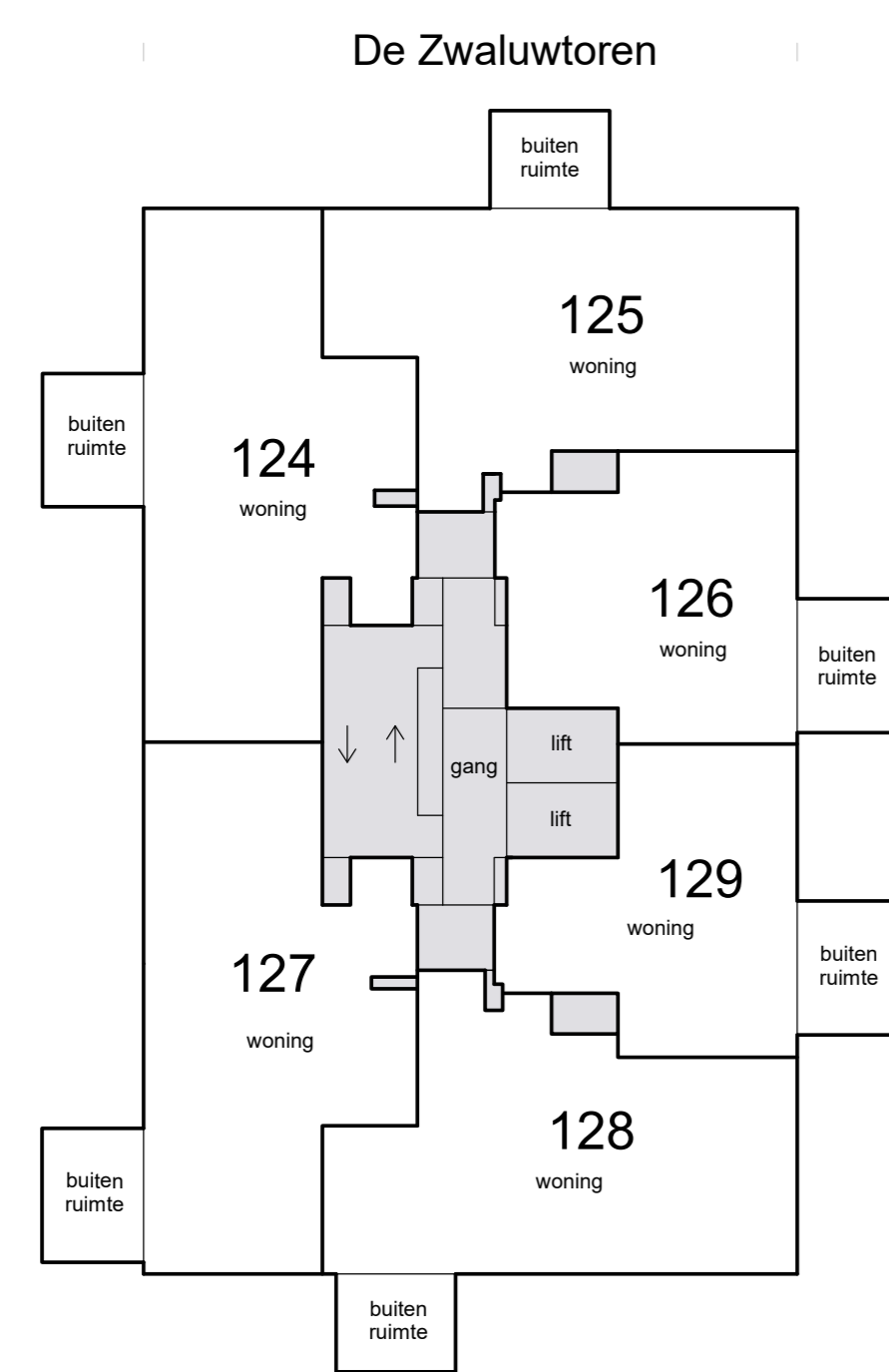
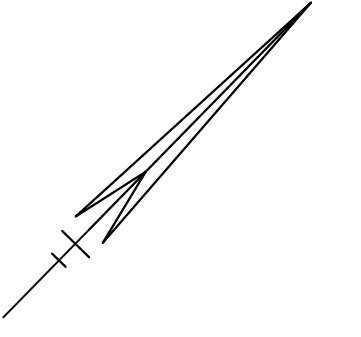

13e etage

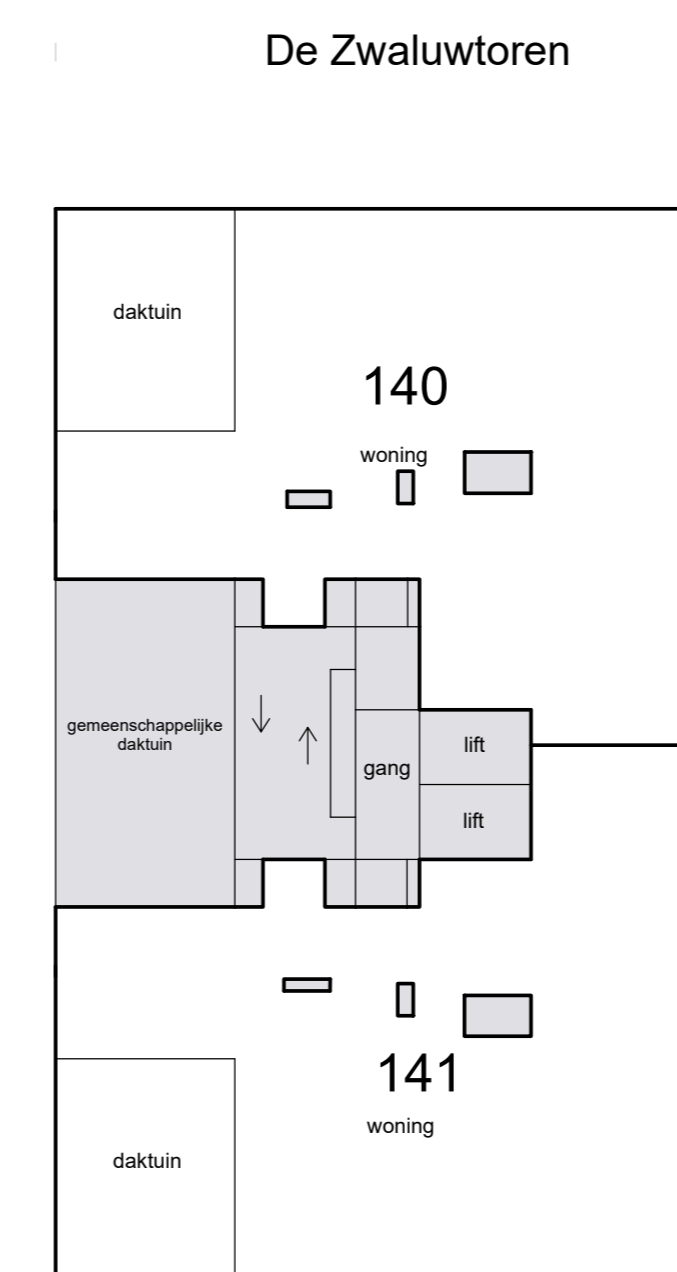

16e etage

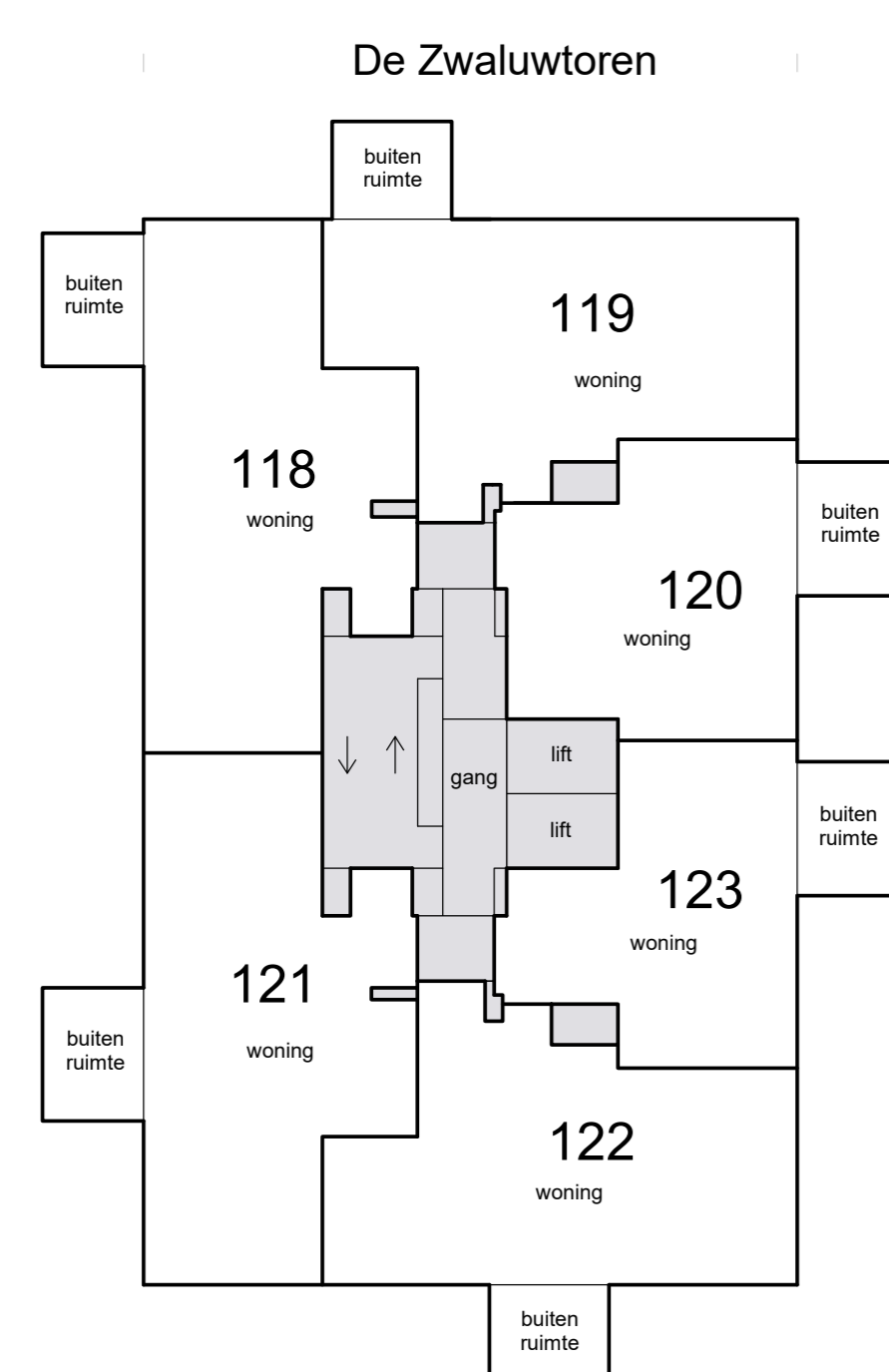

12e etage

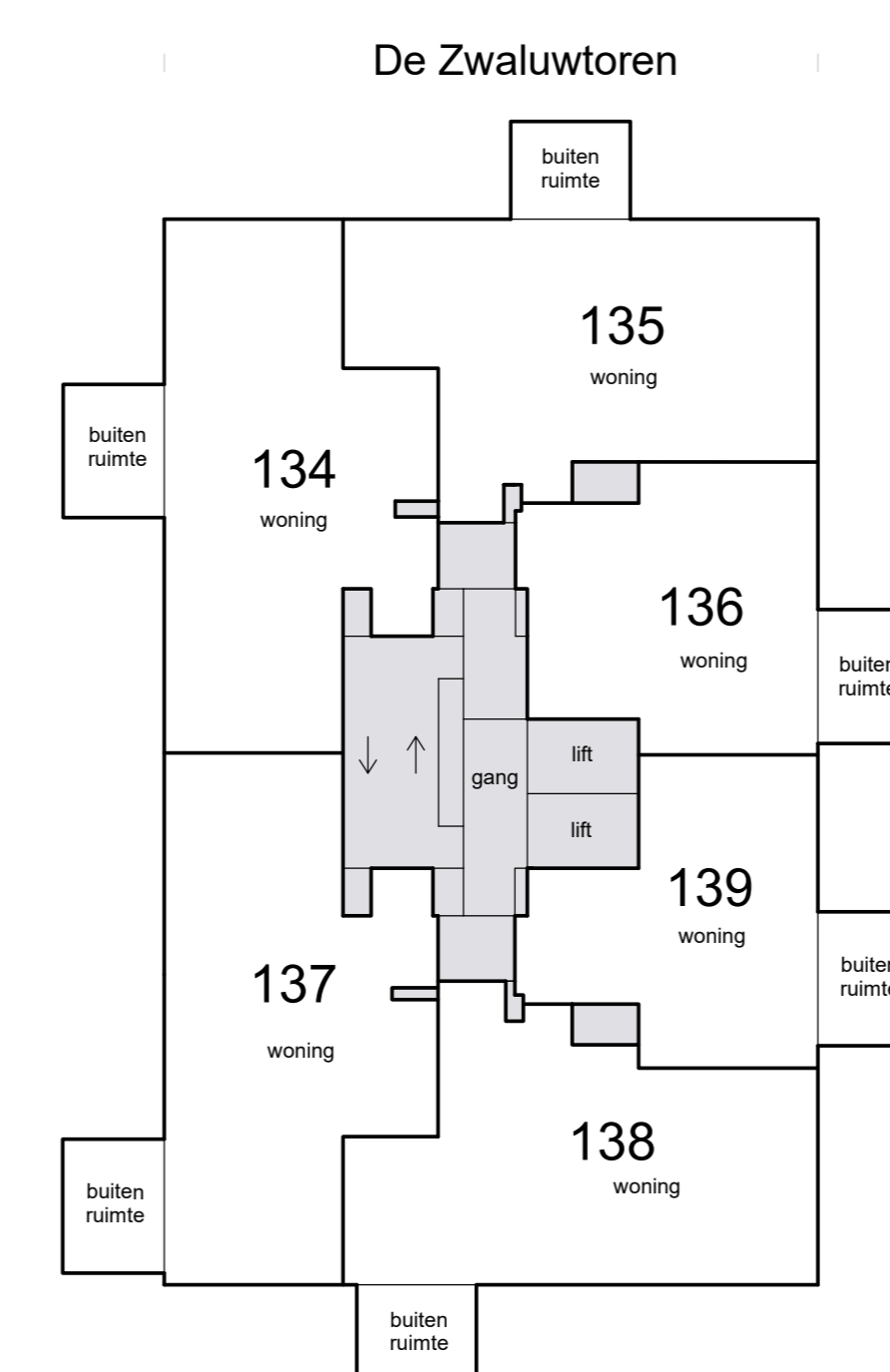

15e etage

